



ATMOS

**UMWELTFREUNDLICHER
HOLZVERGASERHEIZKESSEL**



Modell 2006 / 2007

- SAUGZUGGEBLÄSE
- KERAMIKAUSKLEIDUNG

UMWELTFREUNDLICHER HOLZVERGASERHEIZKESSEL

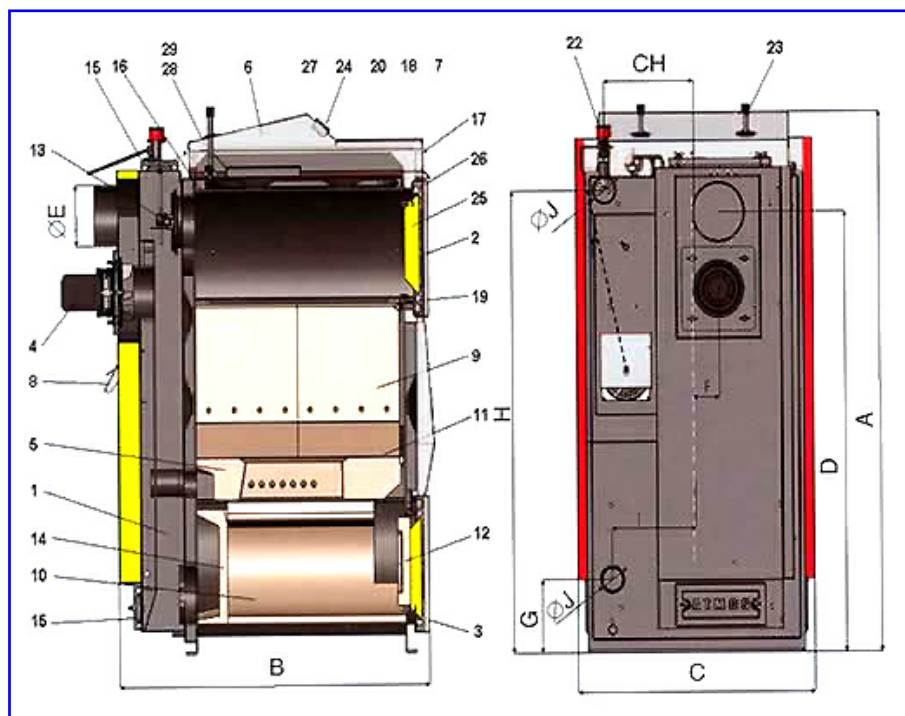

1. Kesselkörper
2. Fülltüre
3. Reinigungstüre
4. Sauglüfter
5. Keramische Luftdüse
6. Schaltfeld
7. Heizthermostat
8. Luftregulierklappe
9. Seitlicher Keramikteil
10. Unterer Keramikteil
11. Dichtung Keramische Luftdüse
12. Keramikteil (Halbmond)
13. Rauchgasklappe
14. Hinterer Keramikteil
15. Reinigungsdeckel
16. Blende
17. Hebel für Rauchgasklappe
18. Thermometer
19. Blende
20. Schalter
22. Feuerungsregler
23. Wärmetauscher
24. Thermostat
25. Fülltürisolierung
26. Türsicherung
27. Rauchgasthermostat
28. Sicherheitsthermostat



ATMOS		DC 15E	DC 18S	DC 20GS	DC 25GS	DC 32GS	DC 40GS	DC 30SE	DC 40SE	DC 50SE	DC 75SE
A	mm	1120	1120	1200	1200	1200	1350	1200	1300	1300	1420
B	mm	630	770	770	970	970	970	970	970	1170	1470
C	mm	590	590	670	670	670	670	670	770	770	770
D	mm	690	872	946	946	946	1092	946	1046	1046	1153
E	mm	152	152	152	152	152	152	152	152	152	180
F	mm	65	65	75	75	75	75	75	70	75	70
G	mm	200	200	180	180	180	180	180	180	180	180
H	mm	930	930	1000	1000	1000	1100	1000	1100	1100	1100
CH	mm	220	220	255	255	255	305	255	305	305	305
I	mm	190	190	240	240	240	290	240	290	290	290
J		11/2"	11/2"	11/2"	11/2"	11/2"	2"	11/2"	2"	2"	2"

ATMOS		DC 15E	DC 18S	DC 20GS	DC 25GS	DC 32GS	DC 40GS	DC 30SE	DC 40SE	DC 50SE	DC 75SE
Leistung	kW	14,9	20	20	25	32	40	30	40	49	75
Heizfläche	m ²	1,8	1,8	1,9	2,7	2,9	3,2	2,9	3,5	4,2	5,1
Nachfüllvolumen	dm ³	65	66	87	130	130	170	140	190	252	345
Wasserinhalt	Ltr.	45	45	64	80	80	90	80	110	141	171
Heizmaterial	Trockenholz / Heizwert 15 - 18 MJ/kg, Durchmesser 80 - 150 mm, Wasserinhalt 12 - 20%										
Scheitlänge max.	mm	330	330	330	530	530	530	530	530	700	1000
Wirkungsgrad		81 - 88%									
Kesselgewicht	kg	285	293	350	408	415	453	345	460	545	700

DC 15E - keine Saugzuggebläse